

NX I-deas Sheet Metal Design

For the design and layout of sheet metal parts

fact sheet

Siemens PLM Software

www.siemens.com/plm

► Summary

NX® I-deas® Sheet Metal Design is an add-on module within NX I-deas software that augments NX I-deas Master Modeler with an extended set of tools for designing sheet metal parts. Sheet Metal Design provides folding and unfolding, user-definable bend tables, stress reliefs and shrinkage allowance into solid models to help you rapidly design and evaluate sheet metal parts.

Benefits

- Create sheet metal parts
- Fold and unfold sheet metal solid parts to create layouts
- Add sheet metal specific features

Features

- Create panels from wireframe geometry, or extract panels from faces of an existing solid model
- Catalog of sheet metal features helps capture design intent
- Automatically generate flat pattern
- Can design sheet metal part within context of surrounding assembly and check for interferences

Design sheet metal parts

Using the solid modeling capabilities of Master Modeler, Sheet Metal Design incorporates user-definable bend tables, stress reliefs and shrinkage allowance into solid models to help you rapidly design and evaluate sheet metal parts. A catalog of sheet metal features including punches, tabs and other features allows you to add final detail to the part to capture true design intent. The solid sheet metal model can be unfolded and used to create fully associative flat pattern production drawings and numerical control toolpaths for manufacturing.

Sheet metal part modeling

With Sheet Metal Design, sheet metal parts can be quickly designed within the context of the surrounding assembly to allow you to evaluate the part for fit and function. You begin by sketching variational wireframe sections which represent the “panels” of the sheet metal model. Dimensional and geometric constraints are incorporated directly on the section. An alternative workflow approach is to create panels by associatively extracting them from faces of existing solid parts. The sheet metal part is generated by defining bends between the panel sections and specifying a material for the part.

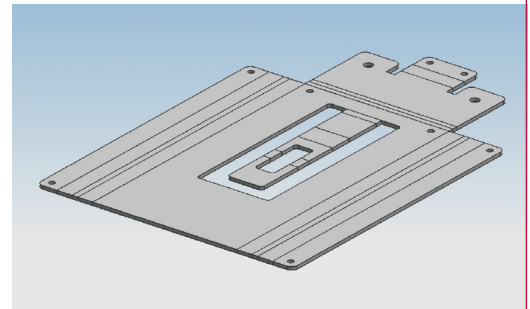
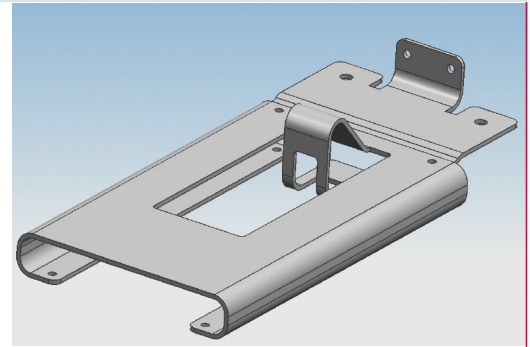

Complex bend modeling tools and a catalog of sheet metal form features allow you to incorporate specific details to capture design intent. Dimension-driven parts make design changes easy.

Sheet metal bending/folding

You can evaluate the flat pattern layout for the sheet metal part. Material growth for the flat pattern is automatically calculated. Material bend allowance can be varied per bend to simulate the effects of using different machines for each bend. The bend allowance (K factor) can be selected from a table-driven materials catalog. Sheet Metal Design also offers tools for modeling of situations such as welded joints, zero radius bends and bends of any angle. The part can be partially unfolded and refolded in any order. Folding capabilities include:

- Automatic unfolding/folding with a single command allows for evaluation of the sheet metal part in any state
- Material bend tables allow you to select appropriate bend allowances for particular material and thickness
- Independent bend radii allow you to specify the radius of each bend individually.
- 0-degree bends simulate welds
- 180-degree bends simulate reinforcement bends
- Stepping of bends allows you to define tangency between two bends to model parts which have offset panels (S-shaped bends)

Automatic stress reliefs

Automatic stress reliefs help you with stress relief placement by indicating key locations where reliefs are appropriate. Stress reliefs are automatically calculated and placed on the model based on user-specified defaults. The reliefs can easily be modified or deleted from the sheet metal part. A set of standard relief shapes is provided including circular, rectangular, vee, shear and slot.

Sheet metal features catalog

A catalog of standard sheet metal features is included, allowing you to incorporate details on the sheet metal part which are necessary for accurately modeling its intended functionality. The catalog consists of various standard sections, punches, tabs, depressions, channels and louvers commonly found in sheet metal manufacturing. You can create holes and punches across bends in the unfolded state which are associative to the folded state, and incorporate the appropriate material stretch allowance. Standard features include straight and arc bends, dimples, tabs, slots, prick punch, depressions, rimmed holes, louvers and notches.

Product and manufacturing information (PMI), and drafting

Sheet metal parts created by Sheet Metal Design can be annotated in either 3D using NX I-deas Master Notation or via 2D drawings with NX I-deas Master Drafting. Sheet metal parts can be easily documented in their folded and unfolded states. Drawings are automatically created from the sheet metal solid, with complete representation of bend lines, material growth and associated features. All geometry is completely associative to the solid part for rapid updating of design changes.



Contact

Siemens PLM Software

Americas 800 498 5351

Europe 44 (0) 1276 702000

Asia-Pacific 852 2230 3333

www.siemens.com/plm